

TSAN 052 HiPR-900™ Serial Diagnostics Backhaul Dataradio Technical Support

For additional assistance: www.dataradio.com

Within the U.S.A.	1-800-992-7774	International	1-507-833-8819
-------------------	----------------	---------------	----------------

Product: HiPR-900

Application: This document provides a method to backhaul the serial diagnostics from the master synch radio to a designated remote HiPR in the router mode.

In some SCADA applications it may be desirable to collect on line diagnostics for trending purposes. In router mode, the master synch radio "sees" the traffic to and from all of the remotes. Therefore, the master synch radio provides the optimum location to collect the diagnostics from the remotes. However, the master synch radio may not be located at the same location as the server which is collecting the diagnostic information.

This configuration does not allow a serial PLC connection at the master synch radio location.

Background: Online Diagnostics is based on information gathered from all receive payload packets that have been accepted by a HiPR's Airlink (RF transmit and receive link). Every HiPR unit (master or remote) thus builds up information on its reception quality.

Every remote embeds its own online diagnostic information in every packet that it sends to the master.

For a unit (master or remote) to accumulate online diagnostic information, it must receive IP traffic.

In Router mode, only some "maintenance" packets (RIP, etc.) are explicitly sent as IP broadcasts. Most traffic is typically sent as unicast IP traffic. Therefore, in this mode the Airlink will reject all receive payload packets that are not addressed to it. It will only accept the few broadcast packets it receives and the unicast packets for which it is the destination.

This means that for a remote unit to accumulate online diags in router mode, the master must have sent it at least some traffic (typically, by SCADA polls).

It also means that the master will only receive a remote's diagnostic information upon receiving packets (data, ACKS, etc.) sent by the remote.

Set Up: The following system (Figure 1) will be used as an example for programming and set up.

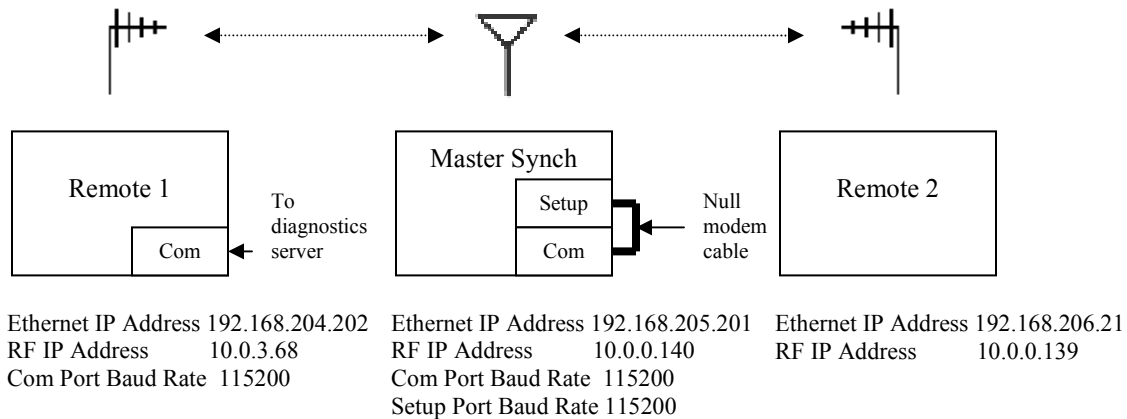

Figure 1

Master Synch Radio Set Up and Programming:

1. The Com Port and Setup Port on the master synch radio are connected via an external RS-232 null modem cable.
2. Configure the Com Port on the Master Synch radio for TCP Client. The Remote IP Address and the Remote IP Port will be the address and port of the remote radio that the diags will be sent to. Set the speed for 115200 baud. The Serial port settings are located under Setup (Basic) > Serial Ports. See Figure 2 for an example.
3. Configure the On Line Diagnostics Thinning Value. The Thinning Value is located under Setup (Basic) > Online Diagnostics. Low Thinning Values are not recommended. A low thinning rate (i.e. 5) may result in excess traffic which will degrade the overall system data throughput. Dataradio suggests starting at 25 and adjusting as necessary to achieve a balance between data and diagnostics throughput.

Serial Ports Setup

SETUP PORT

- Enabled
- Speed: 115200
- Flow Control: None
- Connection Control: Permanent (3-wire)
- IP Gateway Service:
 - CLI Service
 - Serial/RF bridge
 - Online Diagnostics
 - Custom
- IP Gateway Transport: TCP Client
- Local IP Address: 0.0.0.0
- Local IP Port #: 1024
- Remote IP Address: 127.0.0.1
- Remote IP Port #: 6272
- Status: UP

COM PORT

- Enabled
- Speed: 115200
- Flow Control: None
- Connection Control: Permanent (3-wire)
- IP Gateway Service:
 - CLI Service
 - Serial/RF bridge
 - Online Diagnostics
 - Custom
- IP Gateway Transport: TCP Client
- Local IP Address: 0.0.0.0
- Local IP Port #: 6278
- Remote IP Address: 10.0.3.68
- Remote IP Port #: 6278
- Status: UP

([Refresh](#) this frame to confirm "Status")

Figure 2

Remote 1 Port Programming:

1. Configure the Com Port on Remote 1 for Custom, TCP Server and 115200 baud. The Serial port settings are located under Setup (Basic) > Serial Ports. See Figure 3 for an example.
2. Configure the On Line Diagnostics Thinning Value. The Thinning Value is located under Setup (Basic) > Online Diagnostics.

Serial Ports Setup

The screenshot displays two configuration panels: 'SETUP PORT' and 'COM PORT'. Both are checked as 'Enabled'. The 'SETUP PORT' panel has a Speed of 9600, Flow Control set to 'None', and Connection Control set to 'Permanent (3-wire)'. It also shows IP Gateway Service options (CLI Service, Serial/RF bridge, Online Diagnostics, Custom) and IP Gateway Transport settings (TCP Client, Local IP Address 0.0.0.0, Local IP Port # 1024, Remote IP Address 127.0.0.1, Remote IP Port # 23). The status is 'UP'. The 'COM PORT' panel has a Speed of 115200, Flow Control set to 'None', and Connection Control set to 'Permanent (3-wire)'. It also shows IP Gateway Service options (CLI Service, Serial/RF bridge, Online Diagnostics, Custom) and IP Gateway Transport settings (TCP Server, Local IP Address 0.0.0.0, Local IP Port # 6278, Remote IP Address 10.255.255.255, Remote IP Port # 6278). The status is 'READY'. A callout bubble points to the 'COM PORT' Speed field with the text: 'Must match master synch radio Com Port baud rate'. A link at the bottom says '(Refresh this frame to confirm "Status")'.

Figure 3

The following is an example of the diagnostics which may be generated by our sample system.

```
[10.0.0.139] 0, 9, 20, 1, 5, 34, -32, -72, -110, 980, 110
[10.0.0.139] 0, 9, 20, 1, 5, 34, -32, -73, -110, 980, 110
[10.0.0.139] 0, 9, 20, 1, 5, 34, -32, -73, -110, 980, 120
[10.0.3.68] 0, 9, 20, 0, 120, 35, -30, -74, -110, 1000, 110
[10.0.3.68] 0, 9, 20, 0, 120, 35, -30, -74, -110, 1000, 110
[10.0.0.139] 0, 9, 20, 1, 5, 34, -32, -73, -110, 980, 110
[10.0.0.139] 0, 9, 20, 1, 5, 34, -32, -73, -110, 980, 110
[10.0.3.68] 0, 9, 20, 0, 120, 35, -30, -74, -110, 1000, 120
[10.0.3.68] 0, 9, 20, 0, 120, 35, -30, -74, -110, 1000, 110
```

Please refer to the HiPR-900 Users Manual for more information regarding the diagnostics format.